



KLAUS Multiparking GmbH
 Hermann-Krum-Straße 2
 D-88319 Aitrach
 Fon +49 (0) 75 65 5 08-0
 Fax +49 (0) 75 65 5 08-88
 info@multiparking.com
 www.multiparking.com

PRODUCT DATA



multi**base** G82

2000 kg ¹

- Page 1
Section
Dimensions
Car data
- Page 2
Width dim.
without door
- Page 3
Width dim.
with door
Function
- Page 4
Approach
Load plan
- Page 5
Installation
Electrical
installation
- Page 6
Technical
data
- Page 7
To be performed by the customer
Description

Garage without door (basement garage)

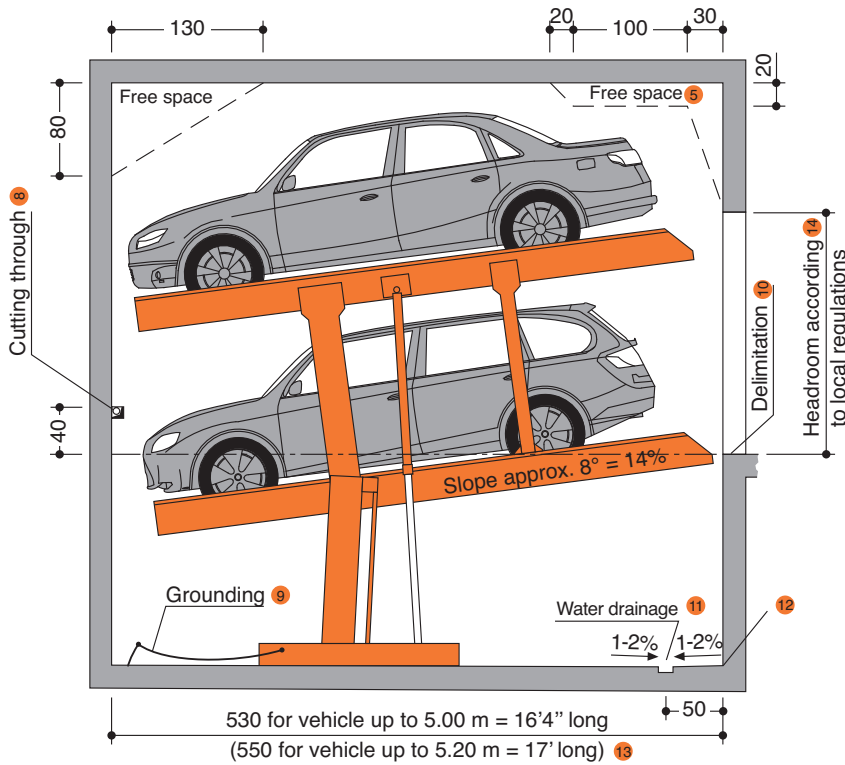

Dimensions

All space requirements are minimum finished dimensions.
 Tolerances for space requirements +3₀. ¹
 Dimensions in cm.
 EB (single platform) = 2 vehicles
 DB (double platform) = 4 vehicles

Suitable for

Standard passenger cars:
 Limousine, station wagon, SUV, van
 according to clearance and maximal
 surface load.

	Standard	Special ²
width	190 cm ⁴	190 cm ⁴
weight	max. 2000 kg	max. 2600 kg
wheel load	max. 500 kg	max. 650 kg

Clearance profile Limousine (L)

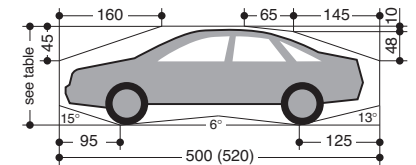

Clearance profile Station wagon (S)

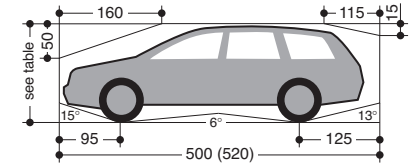

G82-165/295

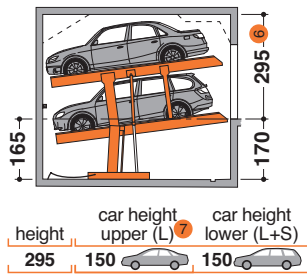

G82-165/305

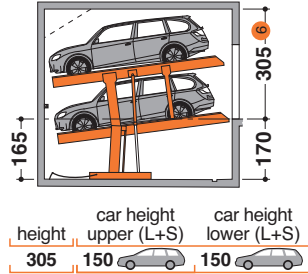

G82-185/310

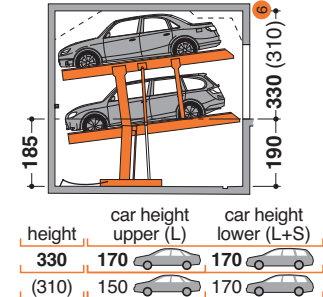

G82-185/325

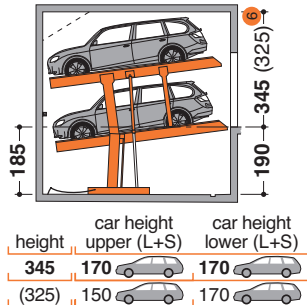

G82-195/320

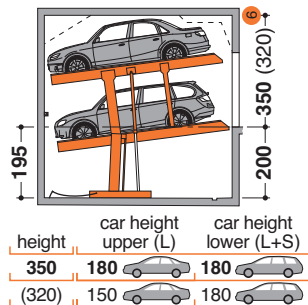

G82-195/335

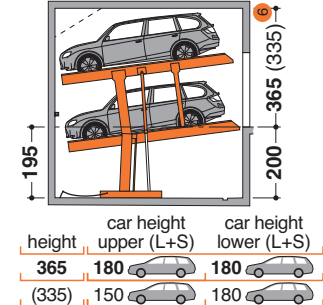

- ¹ Standard type
- ² Special system: maximum load (only EB – upper or lower parking place) for extra charge.
- ³ To follow the minimum finished dimensions, make sure to consider the tolerances according to VOB, part C (DIN 18330 and 18331) and the DIN 18202.
- ⁴ Car width for platform width 230 cm. If wider platforms are used it is also possible to park wider cars.
- ⁵ Free space does not apply for station wagons on upper platform.
- ⁶ If a higher ceiling height is available higher cars can be parked.
- ⁷ L = Limousine / S = Station wagon
- ⁸ For dividing walls: cutting through 10 x 10 cm.
- ⁹ Potential equalization from foundation grounding connection to system (provided by the customer).
- ¹⁰ In compliance with DIN EN 14010, 10 cm wide yellow-black markings compliant to ISO 3864 must be applied by the customer to the edge of the pit in the entry area to mark the danger zone (see „load plan“ page 4).
- ¹¹ Slope with drainage channel and sump.
- ¹² At the transition section between pit floor and walls no hollow mouldings/coverings are possible. If hollow mouldings/coverings are required, the systems must be designed smaller or the pits accordingly wider.
- ¹³ For convenient use of your parking space and due to the fact that the cars keep becoming longer we recommend a pit length of 550 cm.
- ¹⁴ Must be at least as high as the greatest car height + 5 cm.

Page 1
Section
Dimensions
Car data

Page 2
Width dim.
without door

Page 3
Width dim.
with door
Function

Page 4
Approach
Load plan

Page 5
Installation
Electrical
installation

Page 6
Technical
data

Page 7
To be performed
by the customer
Description

Width dimensions for garage without door (basement garage)

Dividing walls

Single Platform (EB)

usable platform width	B1
230	260
240	270
250	280
260	290
270	300

Double Platform (DB)

usable platform width	B1
460	490
470	500
480	510
490	520
500	530

Single and Double Platform (EB + DB) – Example

usable platform width	B1
230 + 460	750
240 + 470	770
250 + 480	790
250 + 500	810
270 + 500	830

Carriageway in accordance with local regulations

Columns in pit

Single Platform (EB)

usable platform width	B2	B3
230	255	245
240	265	255
250	275	265
260	285	275
270	295	285

Double Platform (DB)

usable platform width	B2	B3
460	485	475
470	495	485
480	505	495
490	515	505
500	525	515

Single and Double Platform (EB + DB) – Example

usable platform width	B2	B3
230 + 460	745	735
240 + 470	765	755
250 + 480	785	775
250 + 500	805	795
270 + 500	825	815

Carriageway in accordance with local regulations

Columns outside pit

Single Platform (EB)

usable platform width	B4	B5
230	250	240
240	260	250
250	270	260
260	280	270
270	290	280

Double Platform (DB)

usable platform width	B4	B5
460	480	470
470	490	480
480	500	490
490	510	500
500	520	510

Single and Double Platform (EB + DB) – Example

usable platform width	B4	B5
230 + 460	740	730
240 + 470	760	750
250 + 480	780	770
250 + 500	800	790
270 + 500	820	810

Carriageway in accordance with local regulations

! For parking boxes on the edges and boxes with intermediate walls we recommend our maximum platform width of 270 cm for single platforms and 500 for double platforms. Problems may occur if smaller platform widths are used (depending on car type, access and individual driving behaviour and capability).

For larger limousines and SUV wider driveways are necessary (in particular on the boxes on the sides due to the missing manoeuvring radius).

- Page 1
Section
Dimensions
Car data
- Page 2
Width dim.
without door
- Page 3
Width dim.
with door
Function
- Page 4
Approach
Load plan
- Page 5
Installation
Electrical
installation
- Page 6
Technical
data
- Page 7
To be performed by the customer
Description

Garage with door

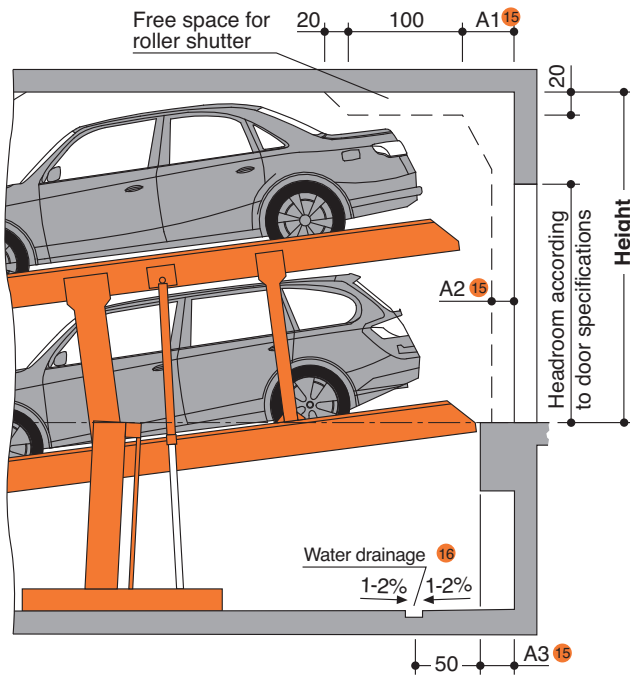

- 15** Dimensions A1, A2 and A3 must be coordinated with the door supplier (provided by the customer).
- 16** Slope with drainage channel and sump.
- 17** Seat-engaging surface (dimensions require coordination with door supplier.) Allround door dimensions require coordination between door supplier and local agency of KLAUS Multiparking.

Width dimensions for garage with door

Single platform (EB)

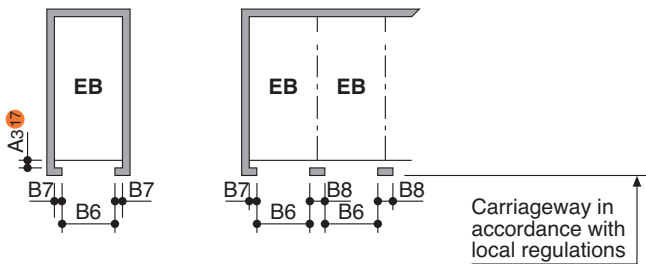

usable platform width	door entrance width B6	B7	B8
230	230	15	30
240	240	15	30
250	250	15	30
260	260	15	30
270	270	15	30

Double platform (DB)

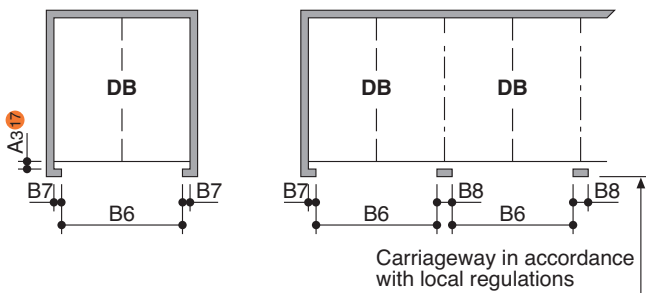

usable platform width	door entrance width B6	B7	B8
460	460	15	30
470	470	15	30
480	480	15	30
490	490	15	30
500	500	15	30

! For parking boxes on the edges and boxes with intermediate walls we recommend our maximum platform width of 270 cm for single platforms and 500 for double platforms. Problems may occur if smaller platform widths are used (depending on car type, access and individual driving behaviour and capability).

For larger limousines and SUV wider driveways are necessary (in particular on the boxes on the sides due to the missing manoeuvring radius).

Function

System lifted

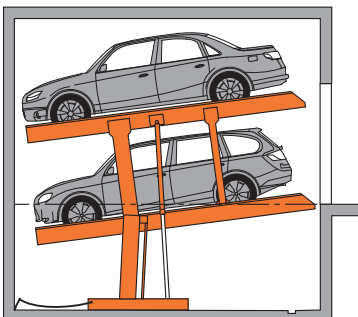

System lowered

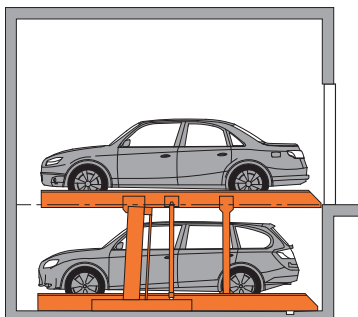

Page 1
Section
Dimensions
Car data

Page 2
Width dim.
without door

Page 3
Width dim.
with door
Function

Page 4
Approach
Load plan

Page 5
Installation
Electrical
installation

Page 6
Technical
data

Page 7
To be performed by the
customer
Description

Approach

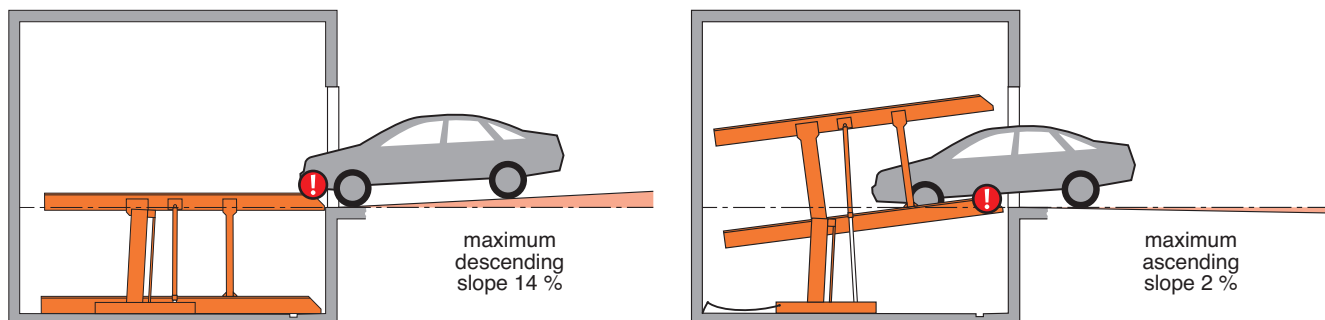

! The illustrated maximum approach angles must not be exceeded. Incorrect approach angles will cause serious manoeuvring & positioning problems on the parking system for which the local agency of KLAUS Multiparking accepts no responsibility.

Load plan

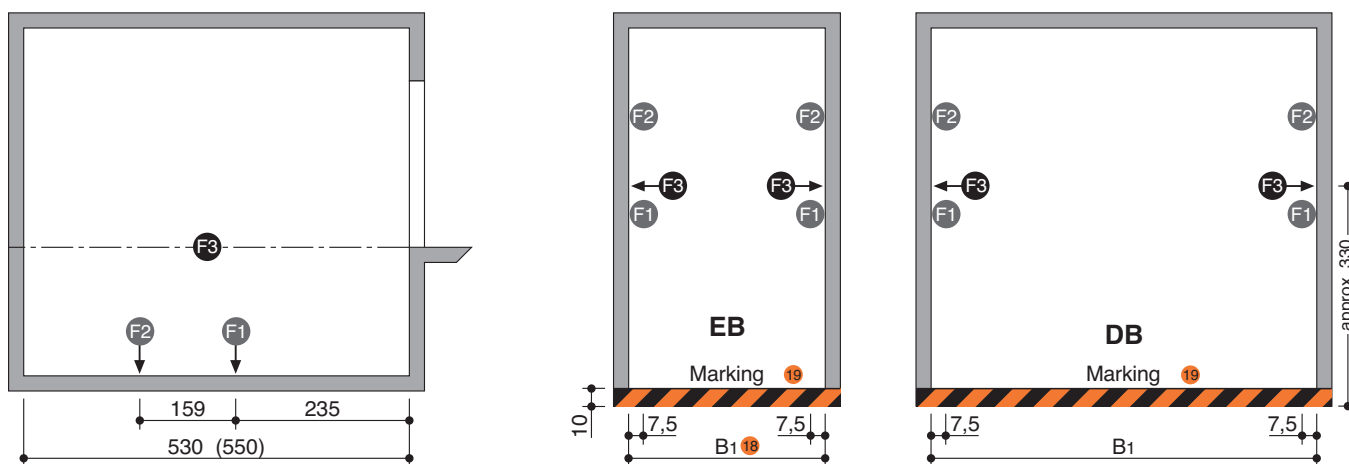

platform load	F1	F2	F3	20
EB 2000 kg	+35,9 -2,7	+8,3 -1,9	±2,3	
EB 2600 kg (upper or lower parking place)	+38,3 -3,1	+9,4 -2,1	±2,5	
DB 2000 kg	+58 -4,7	+19 -3,5	±5,7	

! Units are dowelled to the floor. Drilling depth: approx. 15 cm.

Floor and walls below the drive-in level are to be made of concrete (quality minimum C20/25)!

The dimensions for the points of support are rounded values. If the exact position is required, please contact KLAUS Multiparking.

18 Dimension B1 see page 2

19 Marking compliant to ISO 3864 (colors used in this illustration are not ISO 3864 compliant)

20 All forces in kN

Page 1
Section
Dimensions
Car data

Page 2
Width dim.
without door

Page 3
Width dim.
with door
Function

Page 4
Approach
Load plan

Page 5
Installation
Electrical installation

Page 6
Technical
data

Page 7
To be performed
by the customer
Description

Installation data – Free space for longitudinal and vertical ducts (e.g. ventilation)

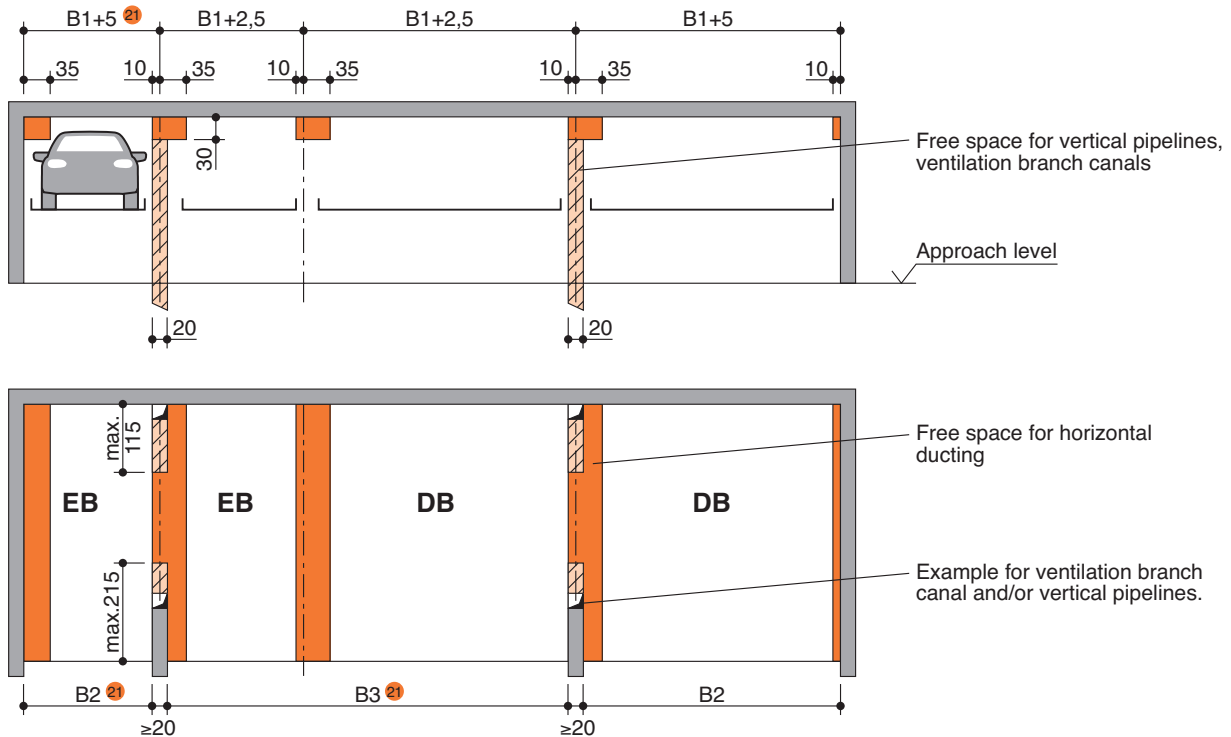

! Free space only applicable if vehicle is parked forwards = FRONT FIRST and driver's door on the left side.

2) Dimensions B1, B2 and B3 see page 2

Electrical installation

Installation diagram

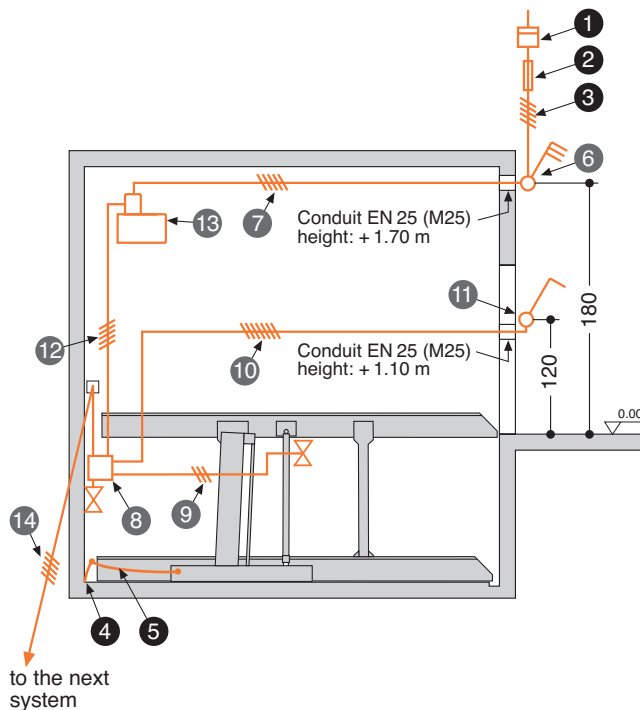

Electrical data (to be performed by the customer)

No.	Quantity	Description	Position	Frequency
1	1	Electricity meter	in the supply line	
2	1	Main fuse: 3 x fuse 16 A (slow) or circuit breaker 3 x 16 A (trigger characteristic K or C)	in the supply line	1 per unit
3	1	Supply line 5 x 2.5 mm ² (3 PH + N + PE) with marked wire and protective conductor	to main switch	1 per unit
4	every 10 m	Foundation earth connector	corner pit floor	
5	1	Equipotential bonding in accordance with DIN EN 60204 from foundation earth connector to the system		1 per system

Electrical data (included in delivery of KLAUS Multiparking)

No.	Description
6	Lockable main switch
7	Supply line 5 x 2,5 mm ² (3 PH + N + PE) with marked wire and protective conductor
8	Terminal box
9	Control line 3 x 0.75 mm ² (PH + N + PE)
10	Control line 7 x 1.5 mm ² with marked wire and protective conductor
11	Operating device
12	Control line 5 x 1.5 mm ² with marked wire and protective conductor
13	Hydraulic unit 3.0 kW, three-phase current, 400 V / 50 Hz
14	Control line 5 x 1.5 mm ² with marked wire and protective conductor

Page 1
Section
Dimensions
Car data

Page 2
Width dim.
without door

Page 3
Width dim.
with door
Function

Page 4
Approach
Load plan

Page 5
Installation
Electrical
installation

Page 6
Technical
data

Page 7
To be performed by the customer
Description

Technical data

Field of application

By default, the system can only be used for a fixed number of users.

If different users use the system – only on the upper parking spaces – (e.g. short-time parkers in office buildings or hotels) the Multiparking system needs to be adjusted. If required, would you please contact us.

Units

Low-noise power units mounted to rubber-bonded-to metal mountings are installed. Nevertheless we recommend that parking system's garage be built separately from the dwelling.

Available documents

- wall recess plans
- maintenance offer/contract
- declaration of conformity
- test sheet on airborne and slid-borne sound

Environmental conditions

Environmental conditions for the area of multiparking systems: Temperature range -10 to $+40^{\circ}$ C. Relative humidity 50% at a maximum outside temperature of $+40^{\circ}$ C.

If lifting or lowering times are specified, they refer to an environmental temperature of $+10^{\circ}$ C and with the system set up directly next to the hydraulic unit. At lower temperatures or with longer hydraulic lines, these times increase.

Sound insulation

According to DIN 4109 (Sound insulation in buildings), para. 4, annotation 4, KLAUS Multiparkings are part of the building services (garage systems).

Normal sound insulation:

DIN 4109, para. 4, Sound insulation against noises from building services.

Table 4 in para. 4.1 contains the permissible sound level values emitted from building services for personal living and working areas. According to line 2 the maximum sound level in personal living and working areas must not exceed 30 dB (A).

Noises created by users are not subject to the requirements (see table 4, DIN 4109).

The following measures are to be taken to comply with this value:

- Sound protection package according to offer/order (KLAUS Multiparking GmbH)
- Minimum sound insulation of building $R'_{W} = 57$ dB (to be provided by customer)

Increased sound insulation (special agreement):

Draft DIN 4109-10, Information on planning and execution, proposals for increased sound insulation.

Agreement: Maximum sound level in personal living and working areas 25 dB (A). *Noises created by users are not subject to the requirements (see table 4, DIN 4109).*

The following measures are to be taken to comply with this value:

- Sound protection package according to offer/order (KLAUS Multiparking GmbH)
- Minimum sound insulation of building $R'_{W} = 62$ dB (to be provided by customer)

Note: User noises are noises created by individual users in our Multiparking systems. These can be noises from accessing the platforms, slamming of vehicle doors, motor and brake noises.

Building application documents

According to LBO and GaVo (garage regulations) the Multiparking systems are subject to approval. We will provide the required building application documents.

Care

To avoid damages resulting from corrosion, make sure to follow our cleaning and care instructions and to provide good ventilation of your garage.

Corrosion protection

See separate sheet regarding corrosion protection.

Railings

If the permissible drop opening is exceeded, railings are to be mounted on the systems. If there are traffic routes next to or behind the installations, railings compliant to DIN EN ISO 13857 must be installed by the customer. Railings must also be in place during construction.

CE Certification

The systems on offer comply with DIN EN 14010 and EC Machine Directive 2006/42/EC. Furthermore, this system underwent voluntary conformity testing by TÜV SÜD.

ZERTIFIKAT ◆ CERTIFICATE ◆ 認証証書 ◆ CERTIFICADO ◆ CERTIFICAT



Certificate concerning the examination of conformity

Certificate no:	KP 332
Certification body:	TÜV SÜD Industrie Service GmbH Zertifizierungsstelle für Produkte der Fördertechnik Gottlieb-Daimler-Str. 7 70794 Filderstadt - Germany
Applicant / Certification holder:	KLAUS Multiparking GmbH Hermann-Krum-Str. 2 88319 Altrach - Germany
Date of application:	2013-12-16
Manufacturer:	KLAUS Multiparking GmbH Hermann-Krum-Str. 2 88319 Altrach - Germany
Product:	Equipment for power driven parking of motor vehicles
Type:	MultiBase G82EB 2.000 kg and 2.600 kg MultiBase G82DB 2.000 kg
Test laboratory:	TÜV SÜD Industrie Service GmbH Prüflaboratorium für Produkte der Fördertechnik Prüfbereich Maschinen der Fördertechnik Gottlieb-Daimler-Str. 7 70794 Filderstadt – Germany
Date and number of the test report / mark of conformity:	2014-10-01 KP 332
Test specifications:	- 2006 / 42 / EC, Annex I - DIN EN 14010
Validity:	This Certificate is valid until 2019-09-30
Result:	The equipment fulfills the requirements of the test specifications for the respective scope of application stated in the annex (page 1) of this certificate, keeping the mentioned conditions.
Date of issue:	2014-10-01

Certification body for lifts and cranes

 Chadi Noureddine





Page 1
Section
Dimensions
Car dataPage 2
Width dim.
without doorPage 3
Width dim.
with door
FunctionPage 4
Approach
Load planPage 5
Installation
Electrical
installationPage 6
Technical
dataPage 7
To be performed by the customer
Description**To be performed by the customer****Safety fences**

Any constraints that may be necessary according to DIN EN ISO 13857 in order to provide protection for the park pits for pathways directly in front, next to or behind the unit. This is also valid during construction. Railings for the system are included in the series delivery when necessary.

Numbering of parking spaces

Consecutive numbering of parking spaces.

Building services

Any required lighting, ventilation, fire extinguishing and fire alarm systems as well as clarification and compliance with the relevant regulatory requirements.

Drainage

For the front area of the pit we recommend a drainage channel, which you connect to a floor drain system or sump (50 x 50 x 20 cm). The drainage channel may be inclined to the side, however not the pit floor itself (longitudinal incline is available). For reasons of environmental protection we recommend to paint the pit floor, and to provide oil and petrol separators in the connections to the public sewage network.

Strip footings

If due to structural conditions strip footings must be effected, the customer shall provide an accessible platform reaching to the top of the said strip footings to enable and facilitate themounting work.

Marking

According to DIN EN 14010, a warning that identifies this danger area must be placed in the entrance area that conforms to ISO 3864. This must be done according to EN 92/58/EWG for systems with a pit (platforms within the pit) 10 cm from the edge of the pit.

Wall cuttings

Any necessary wall cuttings according to page 1.

Electrical supply to the main switch / Foundation earth connector

Suitable electrical supply to the main switch must be provided by the customer during installation. The functionality can be monitored on site by our fitters together with the electrician. If this cannot be done during installation for some reason for which the customer is responsible, the customer must commission an electrician at their own expense and risk.

In accordance with DIN EN 60204 (Safety of Machinery. Electrical Equipment), grounding of the steel structure is necessary, provided by the customer (distance between grounding max. 10 m).

Operating device

Cable conduits and recesses for operating device (for double wing doors: please contact the local agency of KLAUS Multiparking).

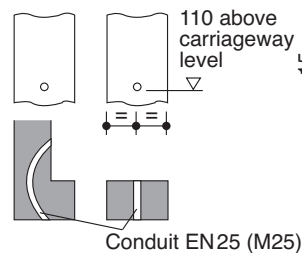
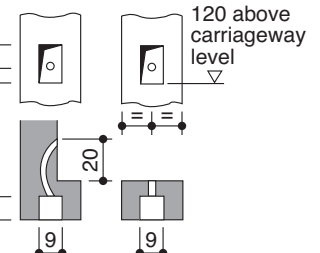
Operating device exposed**Operating device concealed**

If the following are not included in the quotation, they will also have to be provided / paid for by the customer:

- Mounting of contactor and terminal box to the wall valve, complete wiring of all elements in accordance with the circuit diagram
- Costs for final technical approval by an authorized body
- Main switch
- Control line from main switch to hydraulic unit

Description Single platform (EB) and Double platform (DB)**General description**

Multiparking system providing independent parking spaces for 2 cars (EB), 2 x 2 cars (DB), one on top of the other each.

Dimensions are in accordance with the underlying dimensions of parking pit, height and width.

The upper parking bays are accessed horizontally (installation deviation $\pm 1\%$), the lower parking bays inclined (by approx. 8 degrees).

Vehicles are positioned on each parking space using wheel stops on the right side (adjust according to operating instructions).

Operation via operating device with hold-to-run-device using master keys.

The operating elements are usually mounted either in front of the column or on the outside of the door frame

Operating instructions are attached to each operator's stand.

For garages with doors at the front of the parking system the special dimensional requirements have to be taken into account.

Multiparking system consisting of:

- 2 steel pillars with base elements (mounted on the floor)
- 2 sliding platforms (mounted to the steel pillars with sliding bearings)
- 2 platforms
- 1 mechanic synchronization control system (to ensure synchronous operation of the hydraulic cylinders while lowering and lifting the platform)
- 2 hydraulic cylinders
- 2 rigid supports (connect the platforms)
- 1 automatic hydraulic safety valve (prevents accidental lowering of the platform while accessing the platform)
- Dowels, screws, connecting elements, bolts, etc.
- The platforms and parking spaces are end-to-end accessible for parking!

Platforms consisting of:

- Platform base sections
- Adjustable wheel stops
- Canted access plates
- Side members
- Central side member [only DB]
- Cross members
- Safety railings – along the upper and lower platform (if required)
- Screws, nuts, washers, distance tubes, etc.

Hydraulic system consisting of:

- Hydraulic cylinder
- Solenoid valve
- Safety valve
- Hydraulic conduits
- Screwed joints
- High-pressure hoses
- Installation material

Electric system consisting of:

- Operating device (Emergency Stop, lock, 1 master key per parking space)
- Terminal box at wall valve

Hydraulic unit consisting of:

- Hydraulic power unit (low-noise, installed onto a console with a rubber-bonded-to-metal mounting)
- Hydraulic oil reservoir
- Oil filling
- Internal geared wheel pump
- Pump holder
- Clutch
- 3-phase-AC-motor
- Contactor (with thermal overcurrent relay and control fuse)
- Test manometer
- Pressure relief valve
- Hydraulic hoses (which reduce noise transmission onto the hydraulic pipe)

We reserve the right to change this specification without further notice

KLAUS Multiparking reserves the right in the course of technical progress to use newer or other technologies, systems, processes, procedures or standards in the fulfillment of their obligations other than those originally offered provided the customer derives no disadvantage from their so doing.