

### Garage without door (basement garage)

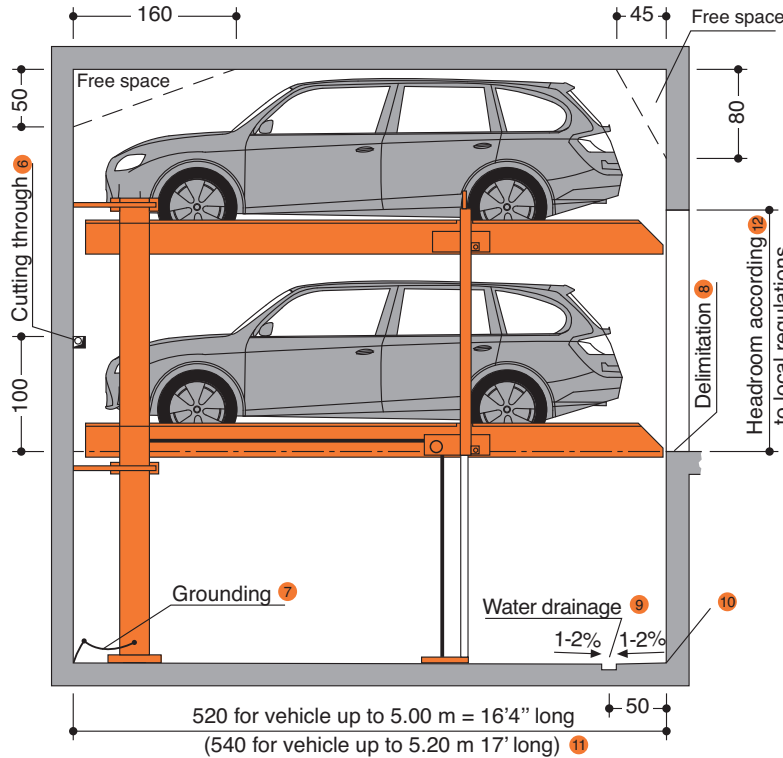

### Dimensions

All space requirements are minimum finished dimensions.

Tolerances for space requirements <sup>3</sup>.  
Dimensions in cm.

EB (single platform) = 2 vehicles  
DB (double platform) = 4 vehicles

### Suitable for

Standard passenger cars:  
Limousine, station wagon, SUV, van  
according to clearance and maximal  
surface load.

	Standard	Special <sup>3</sup>
width	190 cm <sup>4</sup>	190 cm <sup>4</sup>
weight	max. 2000 kg	max. 2600 kg
wheel load	max. 500 kg	max. 650 kg

### Clearance profile

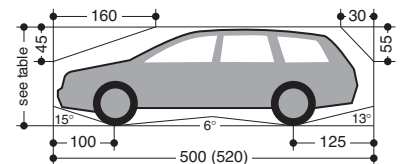

Model	Height	Car Height Upper	Car Height Lower
2072i-165	320	150	150
2072i-170	330 (325)	155	155
2072i-180 <sup>1</sup>	350 (335)	165	165
2072i-185	360 (340)	170	170
2072i-195	380 (350)	180	180
2072i-205	400 (360)	190	190
2072i-215	420 (370)	200	200
2072i-220	430 (375)	205	205
2072i-230	450 (385)	215	215

- Standard type
- Special system: maximum load for extra charge (maximum load for EB up to 3000 kg per place for extra charge).
- To follow the minimum finished dimensions, make sure to consider the tolerances according to VOB, part C (DIN 18330 and 18331) and the DIN 18202.
- Car width for platform width 230 cm. If wider platforms are used it is also possible to park wider cars.
- If a higher ceiling height is available higher cars can be parked.
- For dividing walls: cutting through 10 x 10 cm.
- Potential equalization from foundation grounding connection to system (provided by the customer).
- In compliance with DIN EN 14010, 10 cm wide yellow-black markings compliant to ISO 3864 must be applied by the customer to the edge of the pit in the entry area to mark the danger zone (see „load plan“ page 4).
- Slope with drainage channel and sump.
- At the transition section between pit floor and walls no hollow mouldings/cover are possible. If hollow mouldings/cover are required, the systems must be designed smaller or the pits accordingly wider.
- For convenient use of your parking space and due to the fact that the cars keep becoming longer we recommend a pit length of 540 cm.
- Must be at least as high as the greatest car height + 5 cm.

Page 1  
Section  
Dimensions  
Car data

Page 2  
Width dim.  
without door

Page 3  
Width dim.  
with door  
Function

Page 4  
Approach  
Load plan

Page 5  
Installation  
Electrical  
installation

Page 6  
Technical  
data

Page 7  
To be performed  
by the customer  
Description

## Width dimensions for garage without door (basement garage)

### Dividing walls

#### Single Platform (EB)

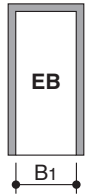

usable platform width	B1
230	260
240	270
<b>250</b>	<b>280</b>
<b>260</b>	<b>290</b>
<b>270</b>	<b>300</b>

#### Double Platform (DB)

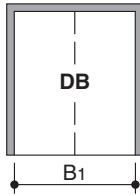

usable platform width	B1
460	490
470	500
480	510
490	520
<b>500</b>	<b>530</b>
<b>510</b>	<b>540</b>
<b>520</b>	<b>550</b>
<b>530</b>	<b>560</b>
<b>540</b>	<b>570</b>

#### Single and Double Platform (EB + DB) – Example

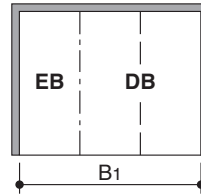

usable platform width	B1
230 + 460	750
240 + 470	770
250 + 480	790
<b>250 + 500</b>	<b>810</b>
<b>270 + 500</b>	<b>830</b>
<b>270 + 510</b>	<b>840</b>
<b>270 + 520</b>	<b>850</b>
<b>270 + 530</b>	<b>860</b>
<b>270 + 540</b>	<b>870</b>

Carriageway in  
accordance with  
local regulations

### Columns in pit

#### Single Platform (EB)

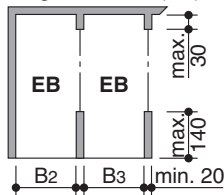

usable platform width	B2	B3
230	255	245
240	265	255
<b>250</b>	<b>275</b>	<b>265</b>
<b>260</b>	<b>285</b>	<b>275</b>
<b>270</b>	<b>295</b>	<b>285</b>

#### Double Platform (DB)

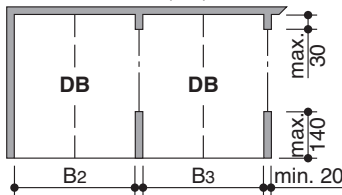

usable platform width	B2	B3
460	485	475
470	495	485
480	505	495
490	515	505
<b>500</b>	<b>525</b>	<b>515</b>
<b>510</b>	<b>535</b>	<b>525</b>
<b>520</b>	<b>545</b>	<b>535</b>
<b>530</b>	<b>555</b>	<b>545</b>
<b>540</b>	<b>565</b>	<b>555</b>

#### Single and Double Platform (EB + DB) – Example

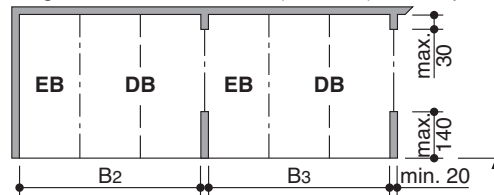

usable platform width	B2	B3
230 + 460	745	735
240 + 470	765	755
250 + 480	785	775
<b>250 + 500</b>	<b>805</b>	<b>795</b>
<b>270 + 500</b>	<b>825</b>	<b>815</b>
<b>270 + 510</b>	<b>835</b>	<b>825</b>
<b>270 + 520</b>	<b>845</b>	<b>835</b>
<b>270 + 530</b>	<b>855</b>	<b>845</b>
<b>270 + 540</b>	<b>865</b>	<b>855</b>

Carriageway in  
accordance with  
local regulations

### Columns outside pit

#### Single Platform (EB)

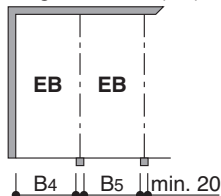

usable platform width	B4	B5
230	250	240
240	260	250
<b>250</b>	<b>270</b>	<b>260</b>
<b>260</b>	<b>280</b>	<b>270</b>
<b>270</b>	<b>290</b>	<b>280</b>

#### Double Platform (DB)

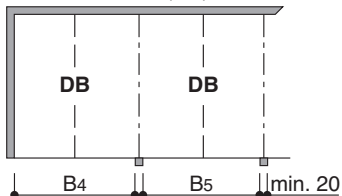

usable platform width	B4	B5
460	480	470
470	490	480
480	500	490
490	510	500
<b>500</b>	<b>520</b>	<b>510</b>
<b>510</b>	<b>530</b>	<b>520</b>
<b>520</b>	<b>540</b>	<b>530</b>
<b>530</b>	<b>550</b>	<b>540</b>
<b>540</b>	<b>560</b>	<b>550</b>

#### Single and Double Platform (EB + DB) – Example

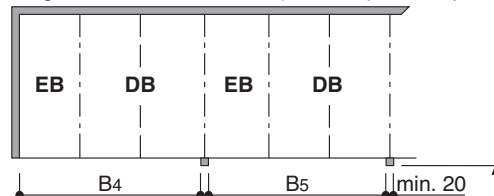

usable platform width	B4	B5
230 + 460	740	730
240 + 470	760	750
250 + 480	780	770
<b>250 + 500</b>	<b>800</b>	<b>790</b>
<b>270 + 500</b>	<b>820</b>	<b>810</b>
<b>270 + 510</b>	<b>830</b>	<b>820</b>
<b>270 + 520</b>	<b>840</b>	<b>830</b>
<b>270 + 530</b>	<b>850</b>	<b>840</b>
<b>270 + 540</b>	<b>860</b>	<b>850</b>

Carriageway in  
accordance with  
local regulations



For parking boxes on the edges and boxes with intermediate walls we recommend our maximum platform width of 270 cm for single platforms and 540 for double platforms. Problems may occur if smaller platform widths are used (depending on car type, access and individual driving behaviour and capability).

For larger limousines and SUV wider driveways are necessary (in particular on the boxes on the sides due to the missing manoeuvring radius).

- Page 1  
Section  
Dimensions  
Car data
- Page 2  
Width dim.  
without door
- Page 3  
Width dim.  
with door  
Function
- Page 4  
Approach  
Load plan
- Page 5  
Installation  
Electrical  
installation
- Page 6  
Technical  
data
- Page 7  
To be performed  
by the customer  
Description

## Garage with door

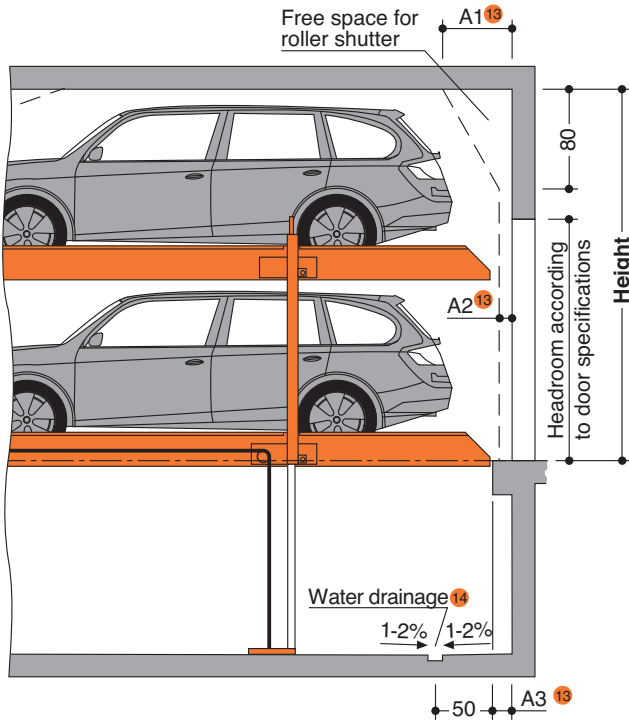

- 13** Dimensions A1, A2 and A3 must be coordinated with the door supplier (provided by the customer).
- 14** Slope with drainage channel and sump.
- 15** Seat-engaging surface (dimensions require coordination with door supplier.) Allround door dimensions require coordination between door supplier and local agency of KLAUS Multiparking.

## Width dimensions for garage with door

### Single platform (EB)

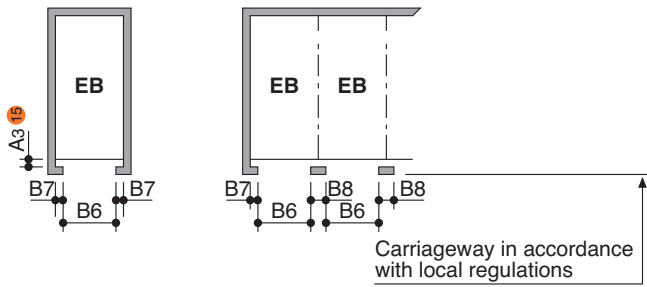

usable platform width	door entrance width B6	B7	B8
230	230	15	30
240	240	15	30
250	250	15	30
260	260	15	30
270	270	15	30

### Double platform (DB)

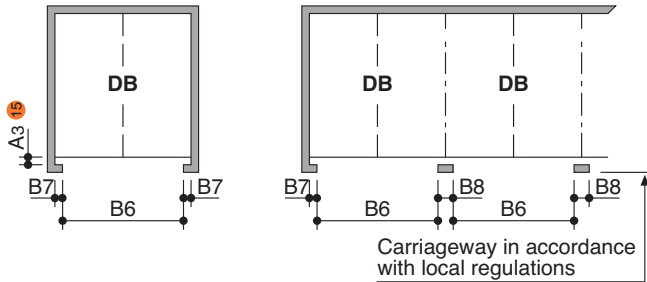

usable platform width	door entrance width B6	B7	B8
460	460	15	30
470	470	15	30
480	480	15	30
490	490	15	30
500	500	15	30
510	510	15	30
520	520	15	30
530	530	15	30
540	540	15	30

**!** For parking boxes on the edges and boxes with intermediate walls we recommend our maximum platform width of 270 cm for single platforms and 540 for double platforms. Problems may occur if smaller platform widths are used (depending on car type, access and individual driving behaviour and capability).

For larger limousines and SUV wider driveways are necessary (in particular on the boxes on the sides due to the missing manoeuvring radius).

## Function

### System lifted

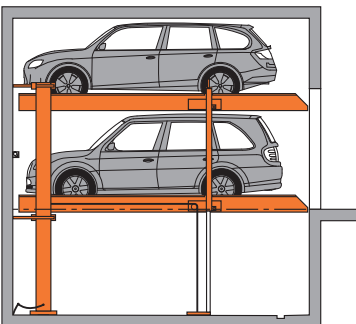

### System lowered

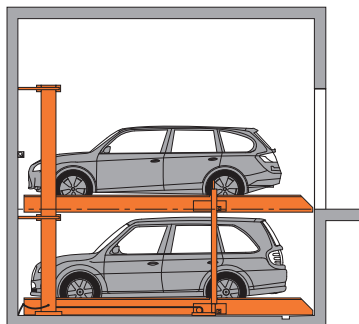

Page 1  
Section  
Dimensions  
Car data

Page 2  
Width dim.  
without door

Page 3  
Width dim.  
with door  
Function

Page 4  
Approach  
Load plan

Page 5  
Installation  
Electrical  
installation

Page 6  
Technical  
data

Page 7  
To be performed by the  
customer  
Description

## Approach

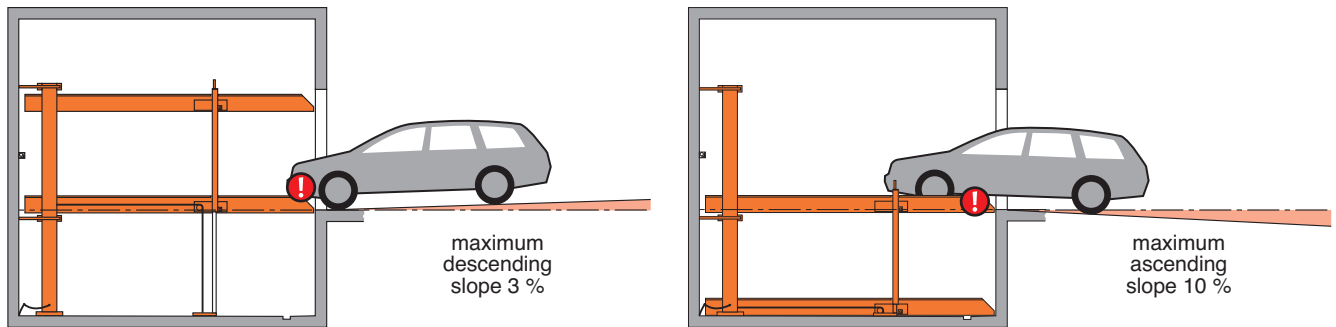

**!** The illustrated maximum approach angles must not be exceeded. Incorrect approach angles will cause serious manoeuvring & positioning problems on the parking system for which the local agency of KLAUS Multiparking accepts no responsibility.

## Load plan

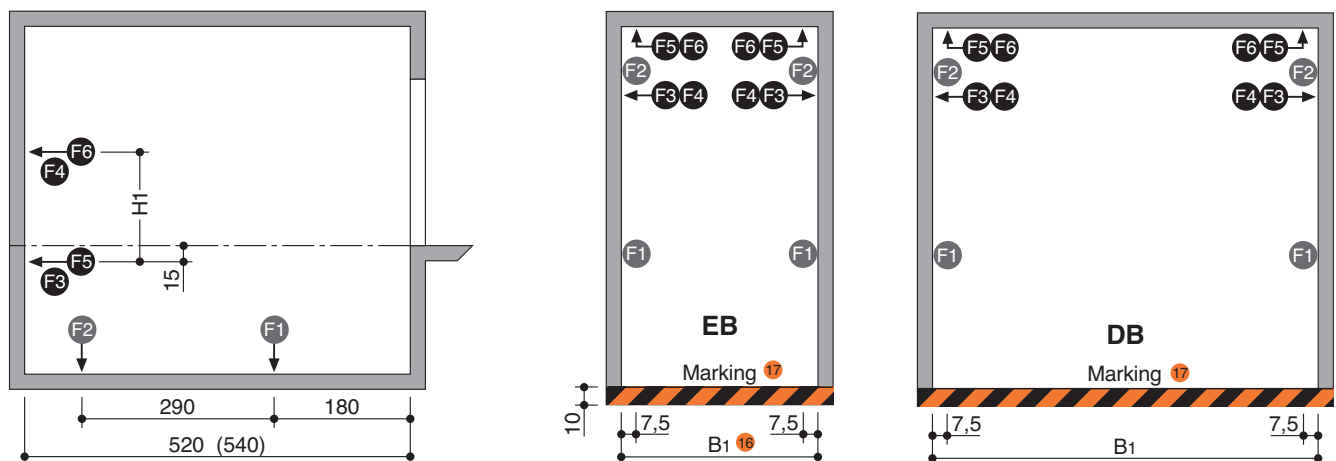

platform load	F1	F2	F3	F4	F5	F6	<sup>18</sup>
EB 2000 kg	+28 -1,7	+12	±1	±0,8	±1,1	±1,1	
EB 2600 kg	+36 -2,2	+15	±1,3	±1	±1,4	±1,4	
EB 3000 kg	+42 -2,4	+17	±1,5	±1,2	±1,6	±1,6	
DB 2000 kg	+51 -6,7	+20	±1,6	±2,6	±2	±2	
DB 2600 kg	+67 -8,6	+26	±2,1	±3,4	±2,6	±2,6	

Type	H1
2072i-165	210
2072i-170	215
2072i-180	225
2072i-185	230
2072i-195	240
2072i-205	250
2072i-215	260
2072i-220	265
2072i-230	275

**!** Units are dowelled to the floor. Drilling depth: approx. 15 cm.  
Floor and walls below the drive-in level are to be made of concrete (quality minimum C20/25)!  
The dimensions for the points of support are rounded values. If the exact position is required, please contact KLAUS Multiparking.

<sup>16</sup> Dimension B1 see page 2

<sup>17</sup> Marking compliant to ISO 3864 (colors used in this illustration are not ISO 3864 compliant)

<sup>18</sup> All forces in kN

Page 1  
Section  
Dimensions  
Car data

Page 2  
Width dim.  
without door

Page 3  
Width dim.  
with door  
Function

Page 4  
Approach  
Load plan

Page 5  
Installation  
Electrical installation

Page 6  
Technical  
data

Page 7  
To be performed  
by the customer  
Description

## Installation data – Free space for longitudinal and vertical ducts (e.g. ventilation)

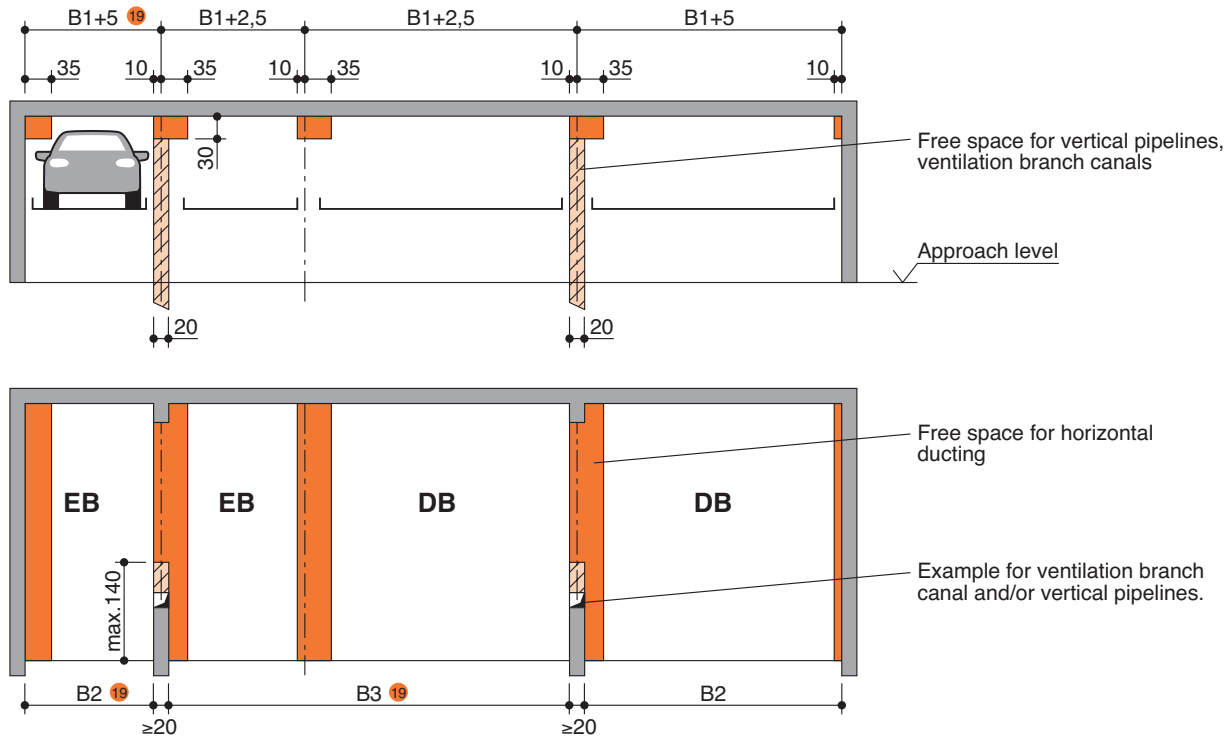

**!** Free space only applicable if vehicle is parked forwards = FRONT FIRST and driver's door on the left side.

<sup>19</sup> Dimensions B1, B2 and B3 see page 2

## Electrical installation

### Installation diagram

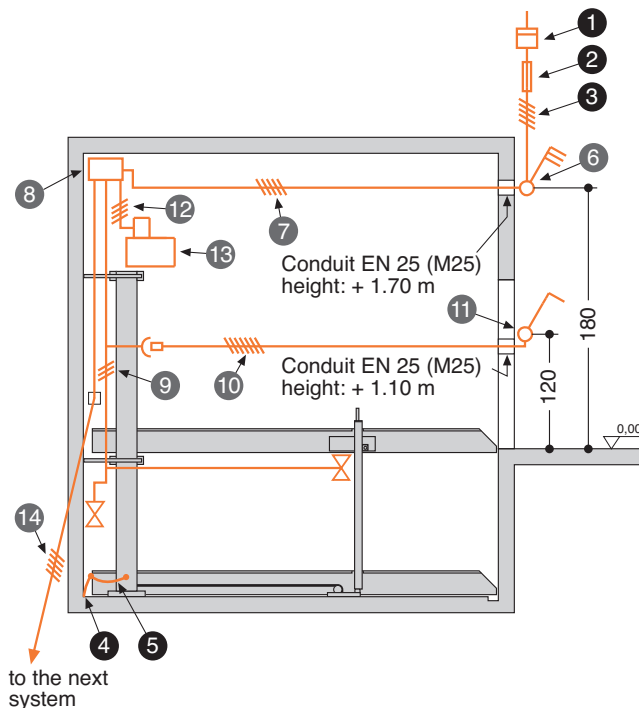

### Electrical data (to be performed by the customer)

No.	Quantity	Description	Position	Frequency
1	1	Electricity meter	in the supply line	
2	1	Main fuse: 3 x fuse 16 A (slow) or circuit breaker 3 x 16 A (trigger characteristic K or C)	in the supply line	1 per 3,0 kW unit
		3 x fuse 20 A (slow) or circuit breaker 3 x 20 A (trigger characteristic K or C)	in the supply line	1 per 5,2 kW unit
3	1	Supply line 5 x 2,5 mm <sup>2</sup> (3 PH + N + PE) with marked wire and protective conductor	to main switch	1 per unit
4	every 10 m	Foundation earth connector	corner pit floor	
5	1	Equipotential bonding in accordance with DIN EN 60204 from foundation earth connector to the system		1 per system

### Electrical data (included in delivery of KLAUS Multiparking)

No.	Description
6	Lockable main switch
7	Supply line 5 x 2,5 mm <sup>2</sup> (3 PH + N + PE) with marked wire and protective conductor
8	Junction box unit
9	Wiring harness multiparking system
10	Connection cable (operating device)
11	Operating device
12	Control line 4 x 2,5 mm <sup>2</sup> with marked wire and protective conductor
13	Hydraulic unit 3,0 kW/5,2 kW, three-phase current, 400 V / 50 Hz <sup>20</sup>
14	Connection cable to the next system

<sup>20</sup> Unit with 5,2 kW only for 2072i DB 2.6 to

Page 1  
Section  
Dimensions  
Car data

Page 2  
Width dim.  
without door

Page 3  
Width dim.  
with door  
Function

Page 4  
Approach  
Load plan

Page 5  
Installation  
Electrical  
installation

Page 6  
Technical  
data

Page 7  
To be performed by the customer  
Description

## Technical data

### Field of application

By default, the system can only be used for a fixed number of users.

If different users use the system – only on the upper parking spaces – (e.g. short-time parkers in office buildings or hotels) the Multiparking system needs to be adjusted. If required, would you please contact us.

### Units

Low-noise power units mounted to rubber-bonded-to metal mountings are installed. Nevertheless we recommend that parking system's garage be built separately from the dwelling.

### Available documents

- wall recess plans
- maintenance offer/contract
- declaration of conformity
- test sheet on airborne and slid-borne sound

### Environmental conditions

Environmental conditions for the area of multiparking systems: Temperature range  $-10$  to  $+40^{\circ}$  C. Relative humidity 50% at a maximum outside temperature of  $+40^{\circ}$  C.

If lifting or lowering times are specified, they refer to an environmental temperature of  $+10^{\circ}$  C and with the system set up directly next to the hydraulic unit. At lower temperatures or with longer hydraulic lines, these times increase.

### Sound insulation

According to DIN 4109 (Sound insulation in buildings), para. 4, annotation 4, KLAUS Multiparkers are part of the building services (garage systems).

#### Normal sound insulation:

DIN 4109, para. 4, Sound insulation against noises from building services.

Table 4 in para. 4.1 contains the permissible sound level values emitted from building services for personal living and working areas. According to line 2 the maximum sound level in personal living and working areas must not exceed 30 dB (A).

*Noises created by users are not subject to the requirements (see table 4, DIN 4109).*

The following measures are to be taken to comply with this value:

- Sound protection package according to offer/order (KLAUS Multiparking GmbH)
- Minimum sound insulation of building  $R'_{W} = 57$  dB (to be provided by customer)

#### Increased sound insulation (special agreement):

Draft DIN 4109-10, Information on planning and execution, proposals for increased sound insulation.

Agreement: Maximum sound level in personal living and working areas 25 dB (A). *Noises created by users are not subject to the requirements (see table 4, DIN 4109).*

The following measures are to be taken to comply with this value:

- Sound protection package according to offer/order (KLAUS Multiparking GmbH)
- Minimum sound insulation of building  $R'_{W} = 62$  dB (to be provided by customer)

Note: User noises are noises created by individual users in our Multiparking systems. These can be noises from accessing the platforms, slamming of vehicle doors, motor and brake noises.

### Building application documents

According to LBO and GaVo (garage regulations) the Multiparking systems are subject to approval. We will provide the required building application documents.

### Care

To avoid damages resulting from corrosion, make sure to follow our cleaning and care instructions and to provide good ventilation of your garage.

### Corrosion protection

See separate sheet regarding corrosion protection.

### Railings

If the permissible drop opening is exceeded, railings are to be mounted on the systems. If there are traffic routes next to or behind the installations, railings compliant to DIN EN ISO 13857 must be installed by the customer. Railings must also be in place during construction.

### CE Certification

The systems on offer comply with DIN EN 14010 and EC Machine Directive 2006/42/EC. Furthermore, this system underwent voluntary conformity testing by TÜV SÜD.

ZERTIFIKAT ◆ CERTIFICATE ◆ 認 証 証 書 ◆ CERTIFICADO ◆ CERTIFICAT



### Certificate concerning the examination of conformity

<b>Certificate no:</b>	KP 454
<b>Certification body:</b>	TÜV SÜD Industrie Service GmbH Zertifizierungsstelle für Produkte der Fördertechnik Gottlieb-Daimler-Str. 7 70794 Filderstadt - Germany
<b>Applicant / Certification holder:</b>	KLAUS Multiparking GmbH Hermann-Krum-Str. 2 88319 Aitrach - Germany
<b>Date of application:</b>	2015-06-12
<b>Manufacturer:</b>	KLAUS Multiparking GmbH Hermann-Krum-Str. 2 88319 Aitrach - Germany
<b>Product:</b>	Equipment for power driven parking of motor vehicles
<b>Type:</b>	MultiBase 2072i / 2078i EB 2.000 kg, 2.600 kg, 3.000 kg MultiBase 2072i / 2078i DB 2.000 kg, 2.600 kg
<b>Test laboratory:</b>	TÜV SÜD Industrie Service GmbH Prüflaboratorium für Produkte der Fördertechnik Prüfbereich Maschinen der Fördertechnik Gottlieb-Daimler-Str. 7 70794 Filderstadt – Germany
<b>Date and number of the test report</b>	2016-08-09 KP 454
<b>mark of conformity:</b>	KP 454
<b>Test specifications:</b>	- 2006 / 42 / EC, Annex I - DIN EN 14010
<b>Validity:</b>	This Certificate is valid until 2021-08-08
<b>Result:</b>	The equipment fulfills the requirements of the test specifications for the respective scope of application stated in the annex (page 1) of this certificate, keeping the mentioned conditions.
<b>Date of issue:</b>	2016-08-09

Certification body "lifts and cranes"



Achim Janocha





Page 1  
Section  
Dimensions  
Car dataPage 2  
Width dim.  
without doorPage 3  
Width dim.  
with door  
FunctionPage 4  
Approach  
Load planPage 5  
Installation  
Electrical  
installationPage 6  
Technical  
dataPage 7  
To be performed by the customer  
Description**To be performed by the customer****Safety fences**

Any constraints that may be necessary according to DIN EN ISO 13857 in order to provide protection for the park pits for pathways directly in front, next to or behind the unit. This is also valid during construction. Railings for the system are included in the series delivery when necessary.

**Numbering of parking spaces**

Consecutive numbering of parking spaces.

**Building services**

Any required lighting, ventilation, fire extinguishing and fire alarm systems as well as clarification and compliance with the relevant regulatory requirements.

**Drainage**

For the front area of the pit we recommend a drainage channel, which you connect to a floor drain system or sump (50 x 50 x 20 cm). The drainage channel may be inclined to the side, however not the pit floor itself (longitudinal incline is available). For reasons of environmental protection we recommend to paint the pit floor, and to provide oil and petrol separators in the connections to the public sewage network.

**Strip footings**

If due to structural conditions strip footings must be effected, the customer shall provide an accessible platform reaching to the top of the said strip footings to enable and facilitate themounting work.

**Marking**

According to DIN EN 14010, a warning that identifies this danger area must be placed in the entrance area that conforms to ISO 3864. This must be done according to EN 92/58/EWG for systems with a pit (platforms within the pit) 10 cm from the edge of the pit.

**Wall cuttings**

Any necessary wall cuttings according to page 1.

**Electrical supply to the main switch / Foundation earth connector**

Suitable electrical supply to the main switch must be provided by the customer during installation. The functionality can be monitored on site by our fitters together with the electrician. If this cannot be done during installation for some reason for which the customer is responsible, the customer must commission an electrician at their own expense and risk.

In accordance with DIN EN 60204 (Safety of Machinery. Electrical Equipment), grounding of the steel structure is necessary, provided by the customer (distance between grounding max. 10 m).

**Operating device**

Cable conduits and recesses for operating device (for double wing doors: please contact the local agency of KLAUS Multiparking).

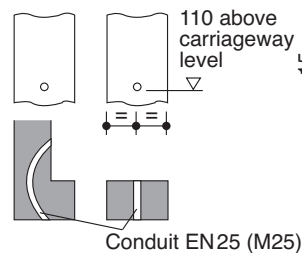
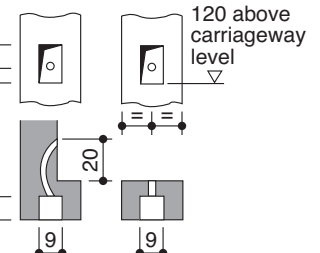
**Operating device exposed****Operating device concealed**

If the following are not included in the quotation, they will also have to be provided / paid for by the customer:

- Mounting of contactor and terminal box to the wall valve, complete wiring of all elements in accordance with the circuit diagram
- Costs for final technical approval by an authorized body
- Main switch
- Control line from main switch to hydraulic unit

**Description Single platform (EB) and Double platform (DB)****General description**

Multiparking system providing independent parking spaces for 2 cars (EB), 2 x 2 cars (DB), one on top of the other each.

Dimensions are in accordance with the underlying dimensions of parking pit, height and width.

The parking bays are accessed horizontally (installation deviation  $\pm 1\%$  for correct drainage of platforms).

Due to the special lifting and bearing construction lifting of the doors is not restricted.

Vehicles are positioned on each parking space using wheel stops on the right side (adjust according to operating instructions).

Operation via operating device with hold-to-run-device using master keys.

The operating elements are usually mounted either in front of the column or on the outside of the door frame.

Operating instructions are attached to each operator's stand.

For garages with doors at the front of the parking system the special dimensional requirements have to be taken into account.

**Multiparking system consisting of:**

- 2 steel pillars (mounted on the floor)
- 2 sliding platforms (mounted to the steel pillars with sliding bearings)
- 2 platforms
- 1 electro-hydraulic synchronization control system (to ensure synchronous operation of the hydraulic cylinders while lowering and lifting the platform)
- 2 hydraulic cylinders
- 2 rigid supports (connect the platforms)
- 2 chains and pocket wheels
- 2 automatic hydraulic safety valves (prevents accidental lowering of the platform while accessing the platform)
- Dowels, screws, connecting elements, bolts, etc.
- The platforms and parking spaces are end-to-end accessible for parking!

**Platforms consisting of:**

- Platform base sections
- Adjustable wheel stops
- Canted access plates
- Side members
- Central side member [only DB]
- Cross members [DB long and short cross members]
- Safety railings - along the upper and lower platform (if required)
- Screws, nuts, washers, distance tubes, etc.

**Hydraulic system consisting of:**

- Hydraulic cylinder
- Solenoid valves
- Safety valves
- Hydraulic conduits
- Screwed joints
- High-pressure hoses
- Installation material

**Electric system consisting of:**

- Operating device (Emergency Stop, lock, 1 master key per parking space)
- Control unit with wiring harness and sensors

**Hydraulic unit consisting of:**

- Hydraulic power unit (low-noise, installed onto a console with a rubber-bonded-to-metal mounting)
- Hydraulic oil reservoir
- Oil filling
- Internal geared wheel pump
- Pump holder
- Clutch
- 3-phase-AC-motor
- Junction box unit with contactor, motor protection switch and control fuse
- Test manometer
- Pressure relief valve
- Hydraulic hoses (which reduce noise transmission onto the hydraulic pipe)

**We reserve the right to change this specification without further notice**

KLAUS Multiparking reserves the right in the course of technical progress to use newer or other technologies, systems, processes, procedures or standards in the fulfillment of their obligations other than those originally offered provided the customer derives no disadvantage from their so doing.